

NO.	DATE	REVISION RECORDS	REVISED	REVISION NO.
-	18/OCT/2017	NEWLY ESTABLISHED	H.ISHINAGA	PES-I52-643
-	-	-	-	-
-	-	-	-	-

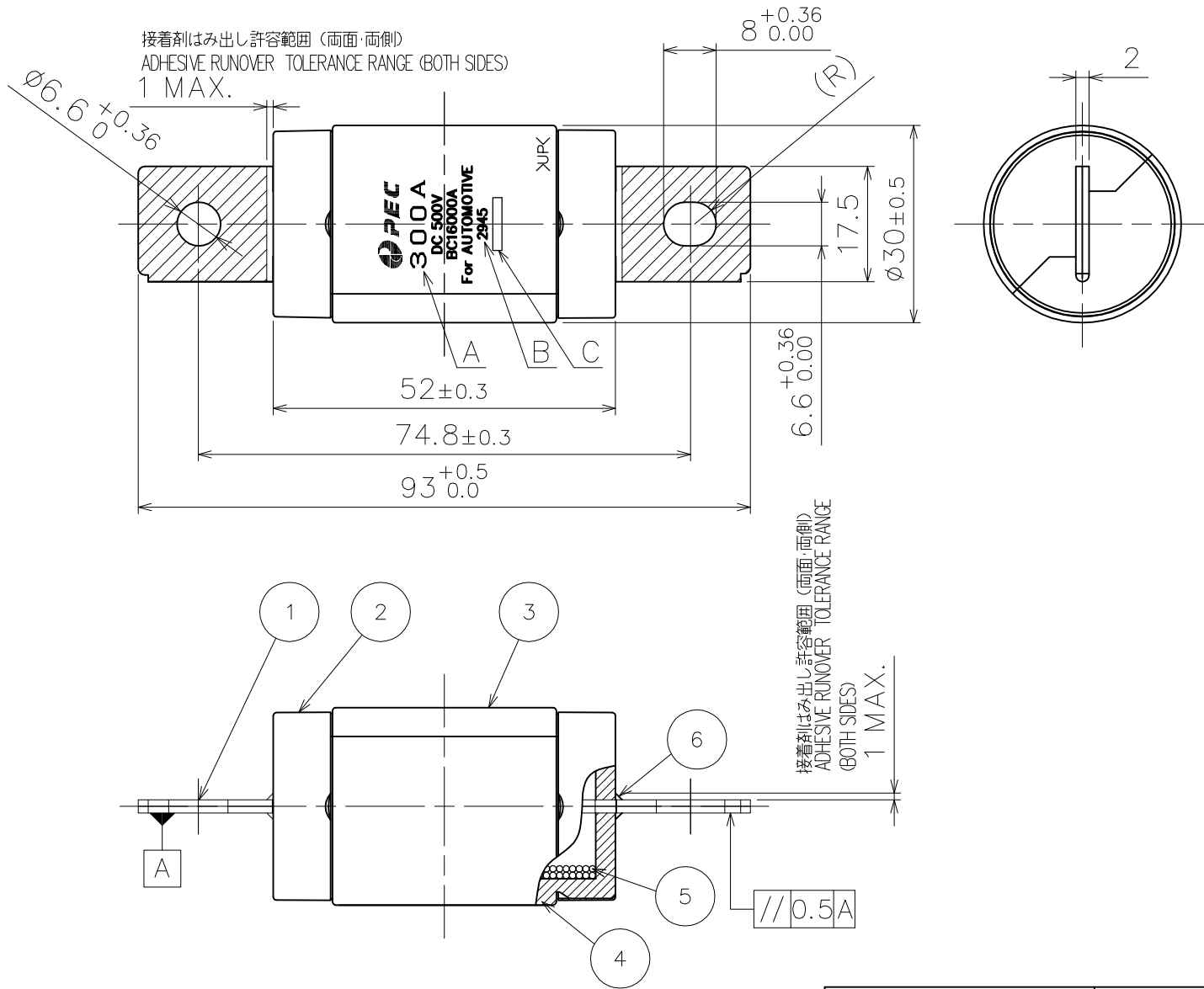

SPECIFICATIONS

- 1. RATED VOLTAGE : 500V DC
- 2. BREAKING CAPACITY : 16000A
- 3. OPERATING TEMPERATURE LIMIT : -40℃...85℃
- 4. STORAGE TEMPERATURE LIMIT : -40℃...85℃
- 5. FUSE PERFORMANCE : PERFORMANCE OF THIS PART CONFORMS TO PES-A52-067.
- 6. FUSE FIXING METHOD : USE TWO M6 BOLTS.
- 7. COMPLY WITH ENVIRONMENTAL RESTRICTION AND PROHIBITION WHICH PRESCRIBED UNDER "PES-02-04".

仕様

- 1. 定格電圧 : 500V DC
- 2. 定格遮断容量 : 16000A
- 3. 使用温度範囲 : -40℃~85℃
- 4. 保管温度範囲 : -40℃~85℃
- 5. 性能 : 太平洋精工規格PES-A52-067に準ずる。
- 6. 固定方法 : M6ボルト2本で固定。
- 7. PES-02-04の環境負荷物質の使用禁止・制限規定を遵守する事。

NOTE

- 1. THE DRAWING ABOVE SHOWS THE 300A FUSE.
- 2. NO ADHESIVE ⑥ FACE OF HATCHING PORTION OF ①. THE CAUTION IS MARKED BY LASER MARKER.
- 4. "A" PORTION SHOWS A RATED CURRENT.
- 5. "B" PORTION SHOWS A PART NUMBER.
- 6. "C" PORTION SHOWS A PRODUCT LOT NUMBER.

注記

- 1. 上図は300Aヒューズを示す。
- 2. ⑥接着剤は①のハッチング面に付着なき事。
- 3. A部には定格電流を表示する。
- 4. B部には製品品番を表示する。
- 5. C部には当社製造Lot No.を表示する。

RATED CURRENT 定格電流	PART No. 品番
150A	29400000
175A	29410000
200A	29420000
225A	29430000
250A	29440000
300A	29450000

6	-	ADHESIVE	-	EPOXY-RESIN	-	-
5	-	ARC-EXTINGUISHING SAND	-	SILICA	-	-
4	-	CASE B	1	UNSATURATED POLYESTER	-	-
3	-	CASE A	1	UNSATURATED POLYESTER	-	-
2	-	RING	2	COPPER	-	-
1	-	ELEMENT	1	COPPER	-	-
NO.	PART NO.	PART NAME	Q'TY	MATERIAL	SIZE	REMARKS

APPROVED	<i>M. Ishinaga</i>	DIMENSION TOLERANCE	ANGULAR TOLERANCE	FINISH	
CHECKED	<i>N. Shibata</i>	±0.2	-	-	
DESIGNED	<i>J. Shimizu</i>	RUST PREVENTION	MATERIAL		
DRAWN	<i>H. Ishinaga</i>	-	SEE TABLE		

SCALE	UNIT	DIAGRAM METHOD	PART NAME
1:1	mm	THIRD ANGLE PROJECTION	EVFP-φ30 ***A(M6)
DRAWING DATE	DRAWING NAME	3D CAD DATA	PART NO.
18/OCT/2017	G2940-0-0	-	SEE TABLE

Pacific Engineering Corporation

SHEET	SIZE
1 / 2	A3

包装仕様 PACKAGING SPECIFICATION

	内装 INNER PACKAGING	外装 OUTER PACKAGING
包装材 MATERIAL	トレー TRAY	ダンボール CARDBOARD BOX (390×260×195)
品番シール SEAL OF PART NO.	—	ID tag
表示 MARKING	該当なし NOT APPLICABLE	
収容数 CAPACITY	16pcs.	80pcs.
重量 WEIGHT	1.5kg	7.5kg
方法 METHOD	<p>1. トレにヒューズを詰める。 2. 段ボールにPEシートを敷く。 3. 段ボールにヒューズを詰めたトレを5段積む。 4. PEシートで包み、一番上にパッドをのせる。 5. テープで封をする。 6. 段ボール側面(現品票貼り付け位置)に現品票を貼る。</p> <p>1.PUT THE FUSES IN THE TRAY. 2.SPREAD A PE SHEET IN THE CARDBOARD BOX. 3.STACK STUFFED TRAY WHICH FILLED WITH FUSES IN 5 LAYERS INTO THE BOX. 4.WRAP THEM BY THE PE SHEET AND PUT A PAD TOP OF THE BOX. 5.SEAL THE BOX BY TAPE. 6.PUT ID TAG ON THE SIDE OF CARDBOARD BOX.</p>	
保管条件 SAFEKEEPING CONDITION	水ぬれ無き事。 湿度：-40℃~85℃、湿度：RH80%以下 NO WET. TEMPERATURE LIMIT: -40℃~85℃、HUMIDITY LIMIT: RH80% MAX.	

NO.	DATE	REVISION RECORDS	REVISED	REVISION NO.
—	18/OCT/2017	NEWLY ESTABLISHED	H.ISHINAGA	PES-I52-643
—	—	—	—	—
—	—	—	—	—

RATED CURRENT 定格電流	PACKAGING PART No. 包装品番
150A	29400001
175A	29410001
200A	29420001
225A	29430001
250A	29440001
300A	29450001

APPROVED		DIMENSION TOLERANCE	ANGULAR TOLERANCE	FINISH	
CHECKED	<i>H. Shibata</i>	±0.2	—	—	
DESIGNED	<i>H. Shimizu</i>	RUST PREVENTION	MATERIAL		
DRAWN	<i>H. Ishinaga</i>	—	SEE TABLE		
SCALE 1:1	UNIT mm	DIAGRAM METHOD 	PART NAME EVFP-φ30 ***A(M6)		
DRAWING DATE 18/OCT/2017	DRAWING NAME G2940-0-0	3D CAD DATA	PART NO. SEE TABLE		
Pacific Engineering Corporation				SHEET	SIZE
				2 / 2	A3

PACKAGING INFORMATION