

NO.	DATE	REVISION RECORDS	REVISED	REVISION NO.
—	—	—	—	—
—	—	—	—	—
—	—	—	—	—

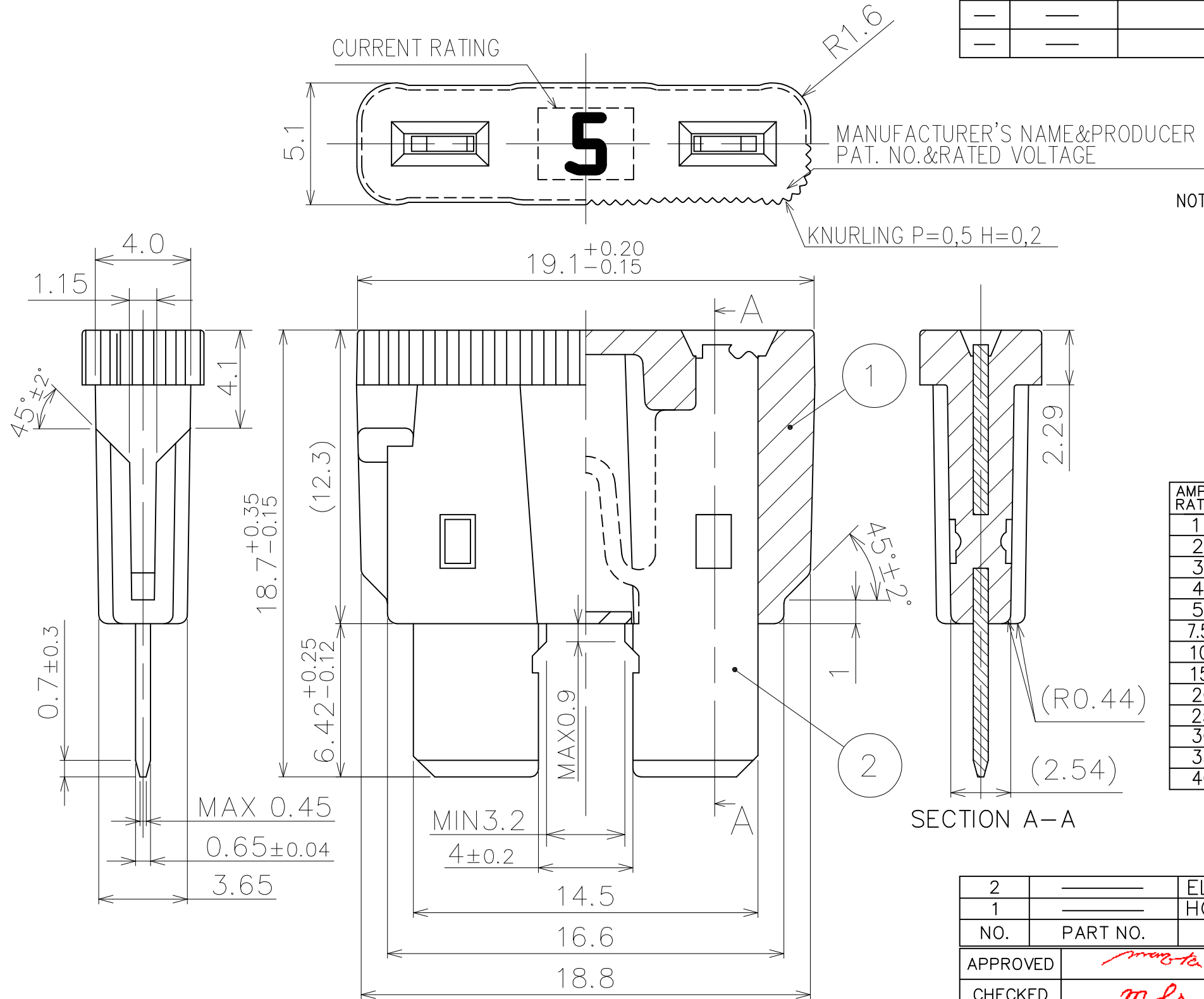

- NOTES; 1.CURRENT RATING MARKED IN WHITE.  
 ALL MARKING MAY BE ROTATED 180°FROM INDICATED POSITION.  
 2.THIS DRAWING SHOWS EXAMPLE FOR INDICATION OF RATED CURRENT 5A.  
 3.REFER TO LETTER'S SPECIFICATION No.ANSI X3,17-1981.  
 4.FUSE ELEMENT IS VISIBLE THROUGH HOUSING.  
 5.DIMENSIONS ARE SYMMETRICAL ABOUT CENTERLINES.  
 6.ELECTORICAL EFFICIENCY PER PES-A47-004.  
 7.ENVIROMENTAL RESTRICTION AND PROHIBITION PRISCRIBED UNDER 'PES-02-04"HAS TO BE COMPLIED.

AMP RATING	PART No.	PACKAGING PART No.	VOLT RATING	COLOR CODE	HOUSING MATERIAL
1	10390000	10390001	32	BLACK	POLYCARBONATE
2	10210000	10210001	32	GRAY	
3	10220000	10220001	32	VIOLET	
4	10230000	10230001	32	PINK	
5	10410000	10410001	32	TAN	
7.5	10420000	10420001	32	BROWN	POLYAMID
10	10430000	10430001	32	RED	
15	10440000	10440001	32	BLUE	
20	10260000	10260001	32	YELLOW	
25	10270000	10270001	32	NATURAL(WHITE)	
30	10280000	10280001	32	GREEN	POLYETHERSULFONE
35	10290000	10290001	32	DARK GREEN	
40	10480000	10480001	32	ORANGE	

FOR EU:  
 THE DECIMAL SEPARATOR IS FULL STOP, AND NOT A COMMA.  
 E.G. EU  $\pi=3,14$  - JAPAN :  $\pi=3.14$

2	—	ELEMENT	1	Zn ALLOY	—	Sn PLATED	
1	—	HOUSING	1	SEE TABLE	—	—	
NO.	PART NO.	PART NAME	Q'TY	MATERIAL	SIZE	REMARKS	
APPROVED	<i>maruta</i>	DIMENSION TOLERANCE		ANGULAR TOLERANCE		FINISH	
CHECKED	<i>mlr</i>	$\pm 0.15$		—		—	
DESIGNED	<i>Daiji Honda</i>	RUST PREVENTION		MATERIAL			
DRAWN	<i>M. Saumabaki</i>	—		SEE TABLE			
SCALE	5:1	UNIT	mm	DIAGRAM METHOD	PART NAME		
				THIRD ANGLE PROJECTION	BFAT-D		
DRAWING DATE	17/OCT/2016	DRAWING NAME	G1026-0-1	3D CAD DATA	PART NO.		
					SEE TABLE		
<b>Pacific Engineering Corporation</b>						SHEET	SIZE
						1 / 2	A3

包装仕様/PACKAGING SPECIFICATION

	内装/INNER PACKAGING	外装/OUTER PACKAGING
包装材 MATERIAL	PLASTIC BAG(230×285)	CARDBOARD BOX(DOUBLE FLUTE) (489×329×184)
品番シール SEAL OF PART No.	—	現品票/ID TAG
表示 MARKING		
収容数 CAPACITY	1,000pcs	12,000pcs
包装方法 METHOD	<p>1. 包装用ビニール袋に、製品1,000ヶを入れて閉じる。</p> <p>2. 段ボール箱にビニール袋を横に6列並べ、それを2段積んで 計12袋入れる。</p> <p>3. 段ボールのフタをPPテープで止め、ダンボールの側面(現品票貼り付け位置)に現品票を貼る。</p> <p>4. 現品票の横に ㊦ の印を赤字で押す。</p> <p>1. PUT 1000 pcs. OF BFAT-D INTO THE PLASTIC BAG AND SEAL THE BAG.</p> <p>2. ARRANGE THE PLASTIC BAG, WHICH CONTAINS 1000 pcs. OF BFAT-D, IN 6 LINES INTO A CARDBOARD BOX AND PILE UP THEM BY 2 LAYERS. THEN THE BOX CONTAINS 12 BAGS.</p> <p>3. SEAL THE CARDBOARD BOX WITH PP TAPE AND PUT THE ID TAG ON THE SIDE OF THE BOX (PRESCRIBED PLACE).</p> <p>4. PUT ㊦ NEXT TO ID TAG. STAMP COLOR: RED</p>	

包装/PACKAGING INFORMATION

NO.	DATE	REVISION RECORDS	REVISED	REVISION NO.
—	—	—	—	—
—	—	—	—	—
—	—	—	—	—

NO.	PART NO.	PART NAME	Q'TY	MATERIAL	SIZE	REMARKS
APPROVED	<i>mazta</i>	DIMENSION TOLERANCE	ANGULAR TOLERANCE	FINISH		
CHECKED	<i>ml</i>	—	—	—		
DESIGNED	<i>Daiji Hondo</i>	RUST PREVENTION	MATERIAL			
DRAWN	<i>M. Saomasaki</i>	—	REFER TO 1/2			
SCALE	UNIT	DIAGRAM METHOD	PART NAME			
5:1	mm	THIRD ANGLE PROJECTION	BFAT-D			
DRAWING DATE	DRAWING NAME	3D CAD DATA	PART NO.			
17/OCT/2016	G1026-0-1	—	REFER TO 1/2			
<b>Pacific Engineering Corporation</b>						SHEET
						2 / 2
						SIZE
						A3